

Section view C-C

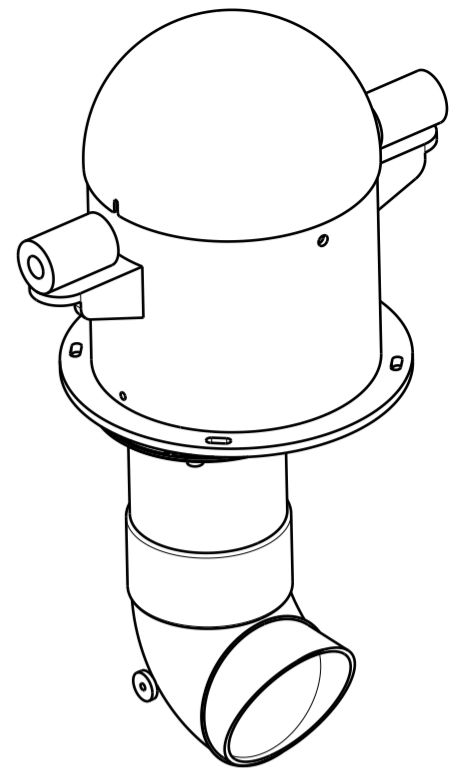

Nº	PART	UNITS
1	ALUMINUM COMPASS HOOD	1
2	125 MM CARD CLASS A COMPASS BOWL	1
3	ALUMINUM BINNACLE	1
4	PERISCOPE TUBE	1
5	MIRROR	1
6	SOFT IRON D-QUADRANTAL CORRECTORS	2
7	MIRROR FIXATION KNURLED NUTS	2

DRAWING	REFERENCIA DEL COMPONENTE	Cant.	Fecha diseño	Unidades	Plano/codigo/norma
02.1714	C20-00128		07/2020	mm	No definido
	Denominacion PIEZA: REFLECTOR TYPE MAGNETIC COMPASS				Peso: Kg.
	REFERENCIA CLIENTE: -----				Sustitue el:
					Sustituido por:
Diseño	CLIENTE: -----	DRAWING PART:			
	PROYECTO:	EQUIPMENT VIEW G			
Tolerancia GENERAL:		Nombre	Fecha	Original en DIN A-2	
±0,1		Dibujado ---	07/2020	Escala: 1:3	
		Comprobado ---		Nivel Diseño 00	